

INSTALLATION GUIDE



PRE-INSTALLATION

- Disconnect power source prior to installation.
- Before adjusting or rotating the head, the screw must be loosened in case of damage to the rubber ring, which can cause water leakage.

DIMENSIONS

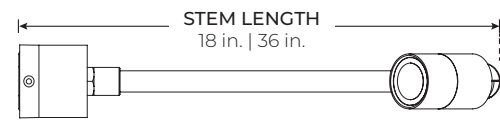
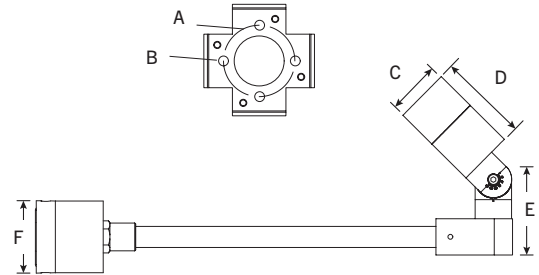

FL-811MP | FL-821MP

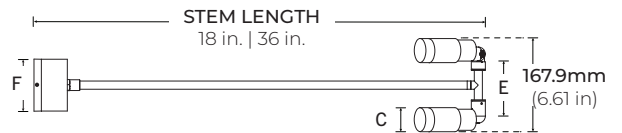

FL-812MP

MODEL	A	B	C	D	E	F
FL-811MP	Ø39.9mm	4 x Ø5.3mm	Ø56.9mm	114.8mm	99.8mm	Ø74.9mm
FL-812MP	Ø79.8mm	4 x Ø6.4mm	Ø56.9mm	114.8mm	252mm	Ø140mm
FL-821MP	Ø39.9mm	4 x Ø5.3mm	Ø85.9mm	168.8mm	79mm	Ø74.9mm

SAFETY

Read all instructions before installation.

These products may present a possible shock, serious injury, or death if improperly installed.

Do not cover fixture with heat insulation gasket or similar materials.



Product should be installed by a qualified electrician.



Product should be installed in accordance with these instructions and current electrical codes.



To reduce the risk of fire or overheating, all connections should be tight and secure.

INSTALLATION

STEP 1 Separate the top and bottom of the Junction Box. Feed the fixture main power cord and thread through the top hole of the junction box cap. Secure in place with a screw nut. (Figure 1)

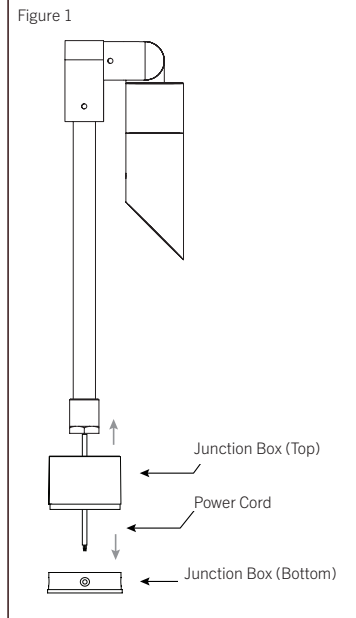

STEP 2 Feed the power cord through hole located at the bottom of the junction box. Connect both halves of the junction box by carefully pressing together. (Figure 2)

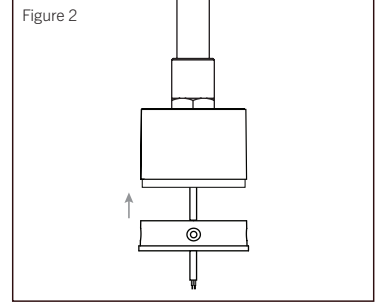

STEP 3 Secure the junction box in place using the provided screws. (Figure 3)

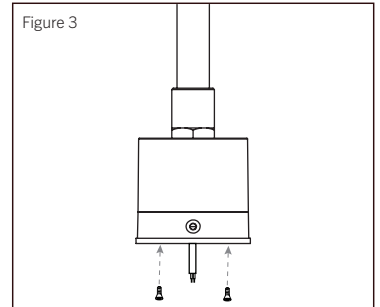

STEP 4 Using a 2.5mm hexagon wrench, remove the mounting plate located under the junction box, and fix the plate to your mounting surface. (Figure 4)

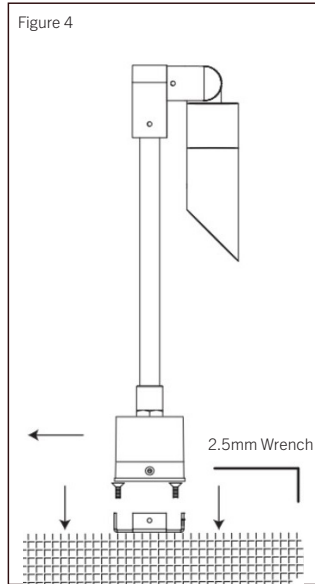

STEP 5 Use the 5mm wrench to loosen the screw if you need to adjust the head vertically. (Figure 5)
After adjusting, the screw must be screwed tightly again.
**Note the caution sticker on the joint.*

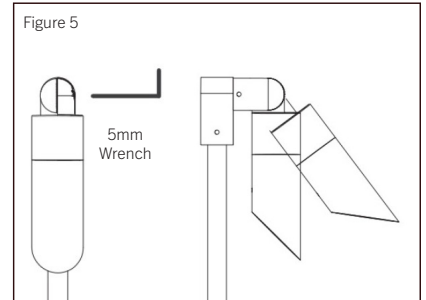

STEP 6 Feed the main power cord through the junction box mounting plate and fit the plate inside the bottom of the junction box. Using a hex key and screws, tightly secure the mounting plate in place along the side. (Figure 6)

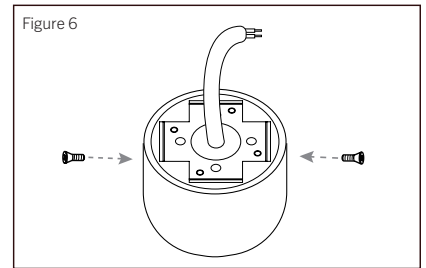

STEP 7 Connect main power cord to the source voltage line.