

FL-801MP

100-277V MINI OUTDOOR LIGHTING LUMINAIRE

Project _____
Location _____
Quote/ Ref # _____

The **FL-801MP** is a miniature, outdoor LED accent light with multiple beam and shroud options. It can individually rotate 360° and can be tilted 180° allowing for a more precise lighting scheme. Various accessories are available for different mounting options. Made of die-cast aluminum, it is extremely durable to ensure a longer lifetime. Suitable for highlighting small objects or surfaces.



SPECIFICATIONS

INPUT VOLTAGE	100-277V AC
WATTAGE	3W
HOUSING	Die-cast Aluminum
GASKET	Silicone Rubber
FRONT COVER	Tempered Glass
LED OPTIC	Polycarbonate Lens
FINISH TYPE	AkzoNobel Powder Coating
DRIVER TYPE	Constant Current
AMBIENT TEMPERATURE	-20 ~ 45°C (-4 ~ 113°F)
IP RATING	IP65
CERTIFICATIONS	ETL

FEATURES

- 100-277V AC
- Adjustable head
- 360° Rotate | 180° Tilt
- Die-cast Aluminum Housing
- IP65 Outdoor/ Wet Rated
- Multiple Beam Patterns



MODEL	WATTS	STEM LENGTH	COLOR TEMP	OPTICS	SHROUD	FINISH	ACCESSORIES
FL-801MP	3 3W	18 18 in.	30K 3000K	15 15°	NS No Shroud	BLK Black	SHV High Voltage Ground Stake
		36 36 in.	40K 4000K	25 25°	AS Angled Retractable	WH White	MR Marine Ambient Corrosion Resistant
			60K 6000K	30 40°		GR Gray	
				3515 H35° x V15°		BZ Bronze	
						SI Silver	

FL-801MP

100-277V MINI OUTDOOR LIGHTING LUMINAIRE

DIMENSIONS

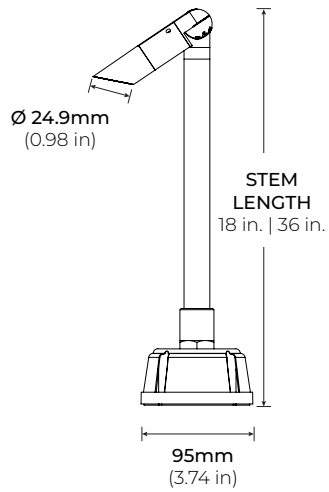

SHROUDS

AS
ANGLED RETRACTABLE

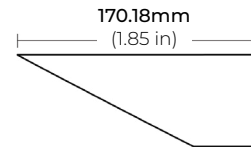

ACCESSORIES

SHV
HIGH VOLTAGE GROUND STAKE

