

FL-730

120V OUTDOOR LIGHTING LUMINAIRE

Project _____
Location _____
Quote/ Ref # _____

The **FL-730** is an outdoor LED accent light with multiple beam and shroud options. It can rotate 360° and can be tilted 180° allowing for a more precise lighting scheme. Various accessories are available for different mounting options. Made of die-cast aluminum, it is extremely durable to ensure a longer lifetime. Its optimized heat dissipation allows the luminaire to be operated in extended lengths of time. Suitable for outdoor lighting such as building facades, gardens, lawns, tree accent lighting, and common outdoor areas.



SPECIFICATIONS

INPUT VOLTAGE	120V AC
WATTAGE	20W/ 30W/ 40W
DIMMING	TRIAC
HOUSING	Die-cast Aluminum
GASKET	Silicone Rubber
LENS	Tempered Glass
FINISH TYPE	Powder Coating
DRIVER TYPE	Constant Current (Built-In)
AMBIENT TEMPERATURE	-20 ~ 45°C (-4 ~ 113°F)
IP RATING	IP65
CERTIFICATIONS	ETL

FEATURES

- 120V AC (No Transformer Needed)
- TRIAC Dimming
- Available in 20W, 30W, and 40W
- Multiple Beam Patterns
- 360° Rotate | 180° Tilt
- Die-cast Aluminum Housing
- IP65 Outdoor/ Wet Rated

LUMENS

WATTS	15° (LM/FT)	25° (LM/FT)	35° (LM/FT)	50° (LM/FT)	50°x20° (LM/FT)
20W	2025	2161	2114	2131	1608
30W	2785	2936	2863	2936	2159
40W	3671	3958	3878	3924	2878



MODEL	WATTS	COLOR TEMP	OPTICS	SHROUD	FINISH	ACCESSORIES	
FL-730	20 20W	27K 2700K	15 15°	NS No Shroud	BLK Black	KA Mounting Bracket A	PJB Tree Strap with Junction Box
	30 30W	30K 3000K	25 25°	AS Angled Glare Shield	WH White	KB Mounting Bracket B	HC Honeycomb Louver
	40 40W	40K 4000K	35 35°	OS Straight Glare Shield	GR Gray	KC 4.5" Round Cover	MR Marine Ambient Corrosion Resistant
		50K 5000K	50 50°	HV H50° x V20°	BZ Bronze	JB Junction Box	PC Pole Clamp
					SI Silver	SHV High Voltage Ground Stake	

FL-730

120V OUTDOOR LIGHTING LUMINAIRE

DIMENSIONS

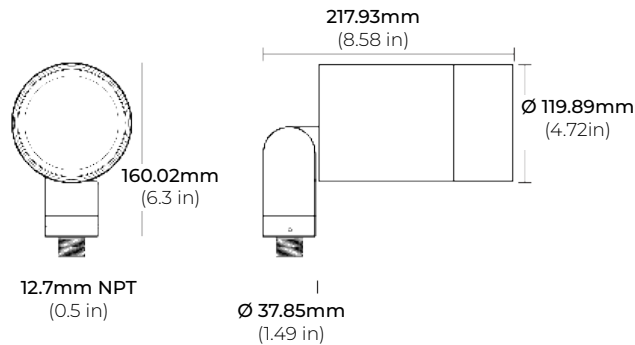

SHROUDS

AS
ANGLED GLARE SHIELD

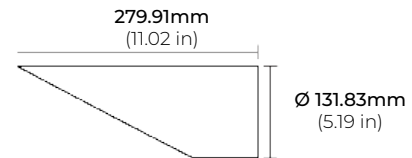

OS
STRAIGHT GLARE SHIELD

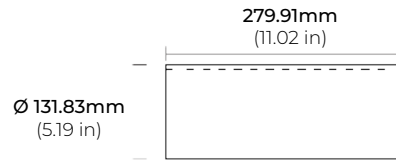

ACCESSORIES

FL700-KA
MOUNTING BRACKET A

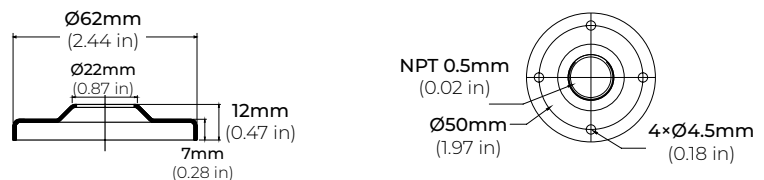

FL700-KB
MOUNTING BRACKET B

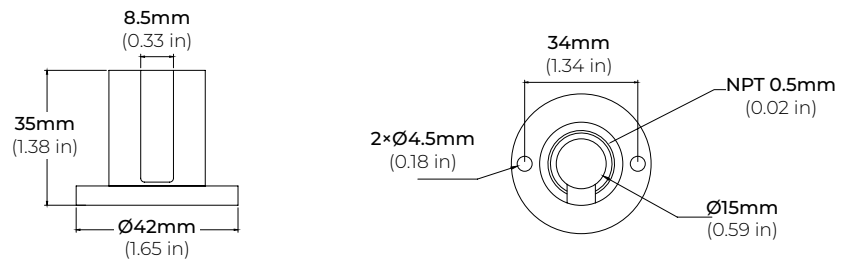

FL700-KC
4.5" ROUND COVER

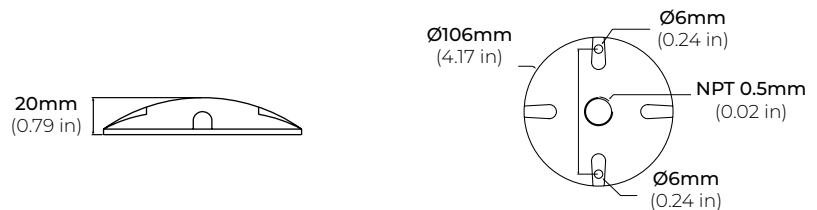

FL-730

120V OUTDOOR LIGHTING LUMINAIRE

ACCESSORIES

FL700-JB
JUNCTION BOX

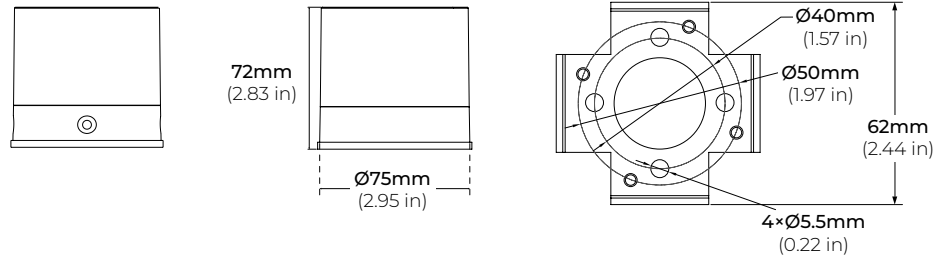

MP-400-SHV
HIGH VOLTAGE GROUND STAKE

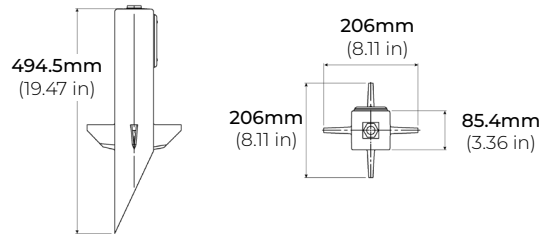

FL700-PJB
TREE STRAP WITH JUNCTION BOX

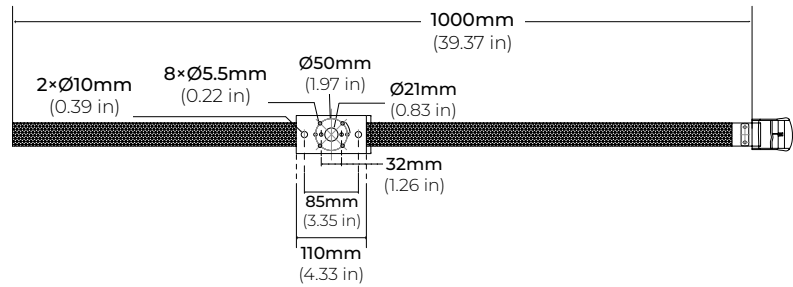

FL700-HC
HONEYCOMB LOUVER

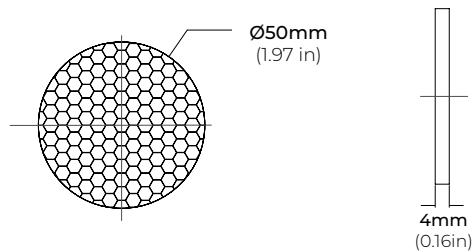

FL700-PC
POLE CLAMP

